

Negative-Feedback Tone Control

By P. J. BAXANDALL

B.Sc.(Eng.)

Independent Variation of Bass and Treble Without Switches

The circuit to be described is the outcome of a prolonged investigation of tone-control circuits of the continuously adjustable type, and provides independent control of bass and treble response by means of two potentiometers, without the need for switches to change over from "lift" to "cut." Unusual features are the wide range of control available and the fact that a level response is obtained with both potentiometers at mid-setting. The treble-response curves are of almost constant shape, being shifted along the frequency axis when the control is operated, and there is practically no tendency for the curves to "flatten off" towards the upper limit of the audio range. The shape of the bass-response curves, though not constant, varies less than with most continuously adjustable circuits.

The "Virtual-Earth" Concept. The performance outlined above has been achieved by the use of a negative-feedback circuit instead of the more usual passive type of network^{1,2} and it is desirable that the reader should become familiar with the "virtual-earth" concept³ as applied to feedback amplifiers, before the operation of the tone-control circuit is considered in detail. The idea behind this concept is quite simple, and may be explained with reference to Fig. 1, in which all irrelevant details such as blocking capacitors, grid bias, etc., have been omitted, and in which V_{in} and V_{out} refer to a.c. components only. If the input resistor, R_{in} is made equal to the feedback resistor, R_{fb} , then the circuit becomes the well-known "see-saw" or "anode-follower" phase splitter^{4,5}, and gives an output voltage which is 180 degrees out of phase with the input voltage and of slightly smaller magnitude. Now the a.c. voltage at the grid is equal to the output voltage divided by the valve gain, which may be 100 or more if the valve is a pentode, so that for

many purposes the grid voltage is negligibly small in comparison with V_{in} and V_{out} . By thus neglecting the grid voltage, the following approximate relationships may be immediately deduced: —

$$I_{in} \approx V_{in} / R_{in} \quad (1)$$

$$I_{fb} \approx V_{out} / R_{fb} \quad (2)$$

where I_{in} and I_{fb} are shown in Fig. 1.

If grid current in the valve is also negligible, which is normally, the case, the application of Kirchhoff's first law (or just common sense!) to the junction of R_{in} and R_{fb} gives $I_{in} - I_{out} = 0$, so that, from (1) and (2): —

$$(V_{in} / R_{in}) - (V_{out} / R_{fb}) \approx 0 \quad \text{i.e.,}$$

$$V_{out} / V_{in} \approx -R_{fb} / R_{in} \quad (3)$$

When the grid voltage is neglected in this way, the grid is often called a "virtual-earth" point, and the use of the concept, though not necessary for dealing with a simple circuit such as Fig. 1, is

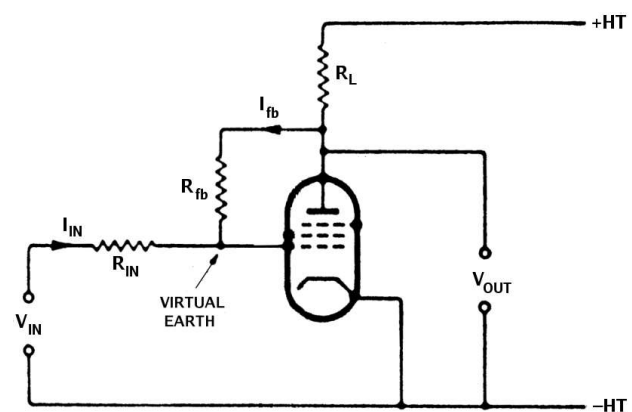

Fig. 1. Simple anode-follower circuit, illustrating the "virtual earth" concept.

found to be very helpful when dealing with more elaborate arrangements, and frequently gives one a far clearer physical picture of what is going on than does a straightforward mathematical analysis. The great practical value of this method of approach appears to have been first fully appreciated by Professor F. C. Williams, who introduced the name "virtual earth."

Treble-Lift Circuit.— The basic circuit used for obtaining treble lift is shown in Fig. 2, in which the potentiometer P is made of sufficiently low resistance to ensure that the voltage at its slider, when the latter is at the middle of the element, is not appreciably affected by the current supplied to C even at the top end of the audio range.

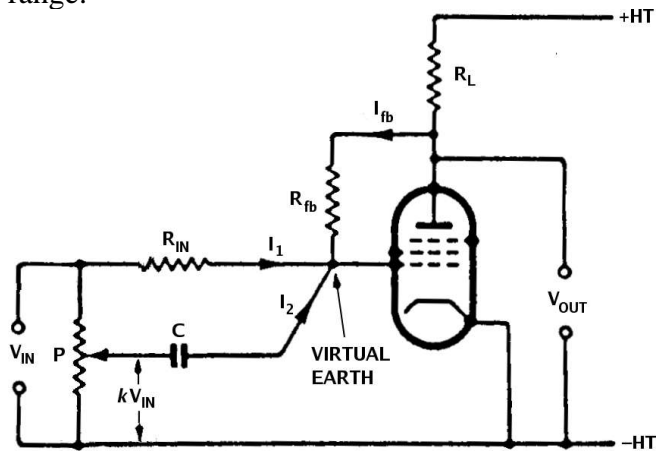

Fig. 2. Basic circuit used for treble lift. R_{IN} is made equal to R_{fb} .

Let k be the fraction of the total potentiometer resistance lying between the slider and earth; then the total input current, I_{in} , flowing towards the virtual earth, is I_1 / I_2 , where I_1 is approximately V_{in}/R_{in} and I_2 is approximately $jkV_{in}\omega C$. The feedback current, I_{fb} , is approximately V_{out}/R_{fb} and the application of Kirchoff's first law to the virtual-earth junction gives $I_1 + I_2 + I_{fb} = 0$ and hence the relationship: —

$$V_{in}/R_{in} + jkV_{in}\omega C + V_{out}/R_{fb} \approx 0$$

which may be rearranged in the form: —

$$V_{out} \approx -V_{in} (R_{fb}/R_{in} + jk\omega CR_{fb}) \quad (4)$$

It will be seen later that in order to combine this treble-lift circuit in a satisfactory manner with the treble-cut circuit, R_{fb} should be made equal to

R_{in} ; then, using R in place of these symbols, equation (4) becomes: —

$$V_{out} \approx -V_{in} (1 + jk\omega CR) \quad (4a)$$

The output voltage may thus be regarded as having two components, one of which is independent of frequency (for a constant value of V_{in}), whereas the other one, leaving in phase by 90 degrees as indicated by the operator "j," has its magnitude proportional to frequency and proportional to the potentiometer setting k .

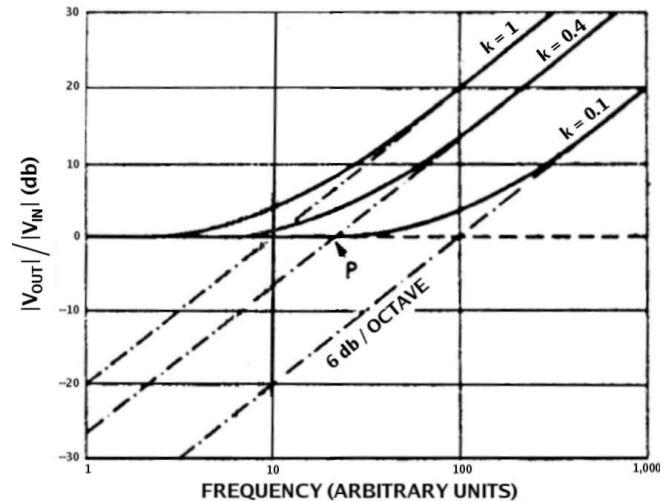

Fig. 3. Diagram showing how the Fig. 2 circuit gives a curve of constant shape but variable position. 0 db represents $V_{out} = V_{in}$. Dotted line—output due to I_1 ; chain dotted—line output due to I_2 ; solid curves—total output.

Plotting $|V_{out}| / |V_{in}|$ in decibels, with the usual logarithmic frequency scale, as shown in Fig. 3, and letting 0 db correspond to $|V_{out}| = |V_{in}|$, the constant term in equation (4a) is represented by a horizontal dotted line through 0 db and the term proportional to frequency is represented by a line such as one of the chain-dotted sloping lines, the position of the line depending on the potentiometer setting k . The full-line curves represent the manner in which the actual total output varies, and it will be noticed that at low frequencies the total output curve is very close to the I_1 curve, whereas at high frequencies, where I_2 is much greater than I_1 , the total curve almost follows the I_2 curve. The effect of varying the potentiometer setting k will be seen to be that of shifting the response curve along the frequency axis. At a point such a "P" the two output

components are of equal magnitude, and because of the 90-degree phase angle between I_2 and I_1 , the total output voltage will be $\sqrt{2}$ times that of each output component, or, in other words, the response will be 3db up.

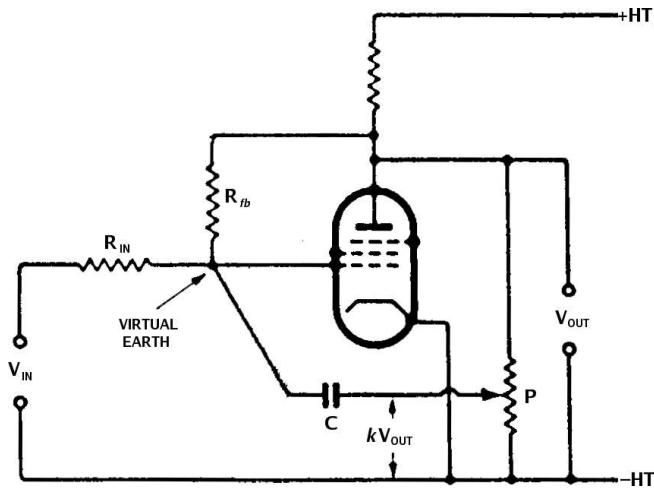

Fig. 4. Basic circuit used for treble cut. R_{fb} is made equal to R_{IN} .

Treble-Cut Circuit.— For treble cut the basic circuit is shown in Fig. 4. The same method of analysis as was used for the treble-lift circuit gives: —

$$V_{in}/R_{in} + V_{out}/R_{fb} + jkV_{out}\omega C \approx 0$$

Hence

$$V_{out} \approx -V_{in} / (R_{in}/R_{fb} + jk\omega CR_{in}) \quad (5)$$

Making R_{fb} equal to R_{in} , as mentioned previously, and using R in place of these symbols, equation (5) becomes: —

$$V_{out} \approx -V_{in} / (1 + jk\omega CR) \quad (5a)$$

Comparing equation (5a) with equation (4a), it will be seen that, for the treble-lift circuit, V_{out} is approximately equal to V_{in} multiplied by $-(1 + jk\omega CR)$, whereas for treble-cut circuit V_{out} is approximately equal to V_{in} divided by $-(1 + jk\omega CR)$. Hence at any particular frequency and potentiometer setting the response of the Fig. 4 circuit will be “down” by the same number of decibels as that of Fig. 2 is “up,” so that the response curves of the two circuits, for each potentiometer setting k , will “mirror images” in

the 0 db line.

Combined Treble-Control Circuit.— In order to obtain treble lift or cut with single-know control, the two circuits just described may be combined by using a centre-tapped potentiometer, which is available commercially in carbon-track form at a price only slightly in excess of that for an ordinary potentiometer. The centre-tap is earthed, one end of the element is connected to the input terminal, the other end is connect to the valve anode (via a coupling capacitor in practice), and the slider is connect to the capacitor C . Then when the slider is on the input side of the centre-tap, the circuit becomes that of Fig.2, and gives treble lift, whilst moving the slider to the anode side of the centre-tap gives the Fig. 4 circuit and provides treble cut. When the slider is at the centre-tap, the capacitor C is joined between virtual earth and actual earth, but the voltage between these two points is so small, when a high-gain valve is used, that the current taken by the capacitor has a negligible effect on the frequency response within the working frequency range.

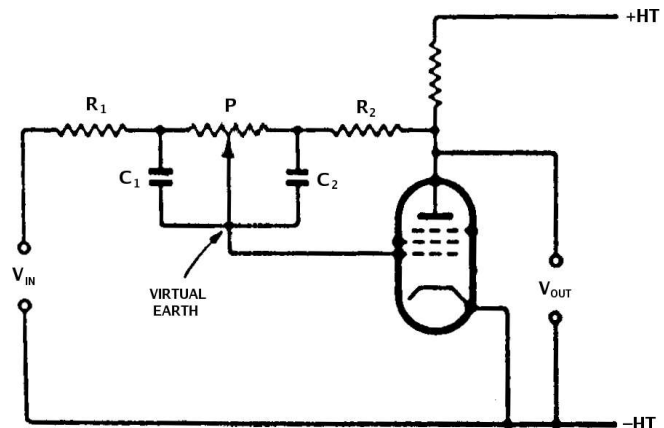

Fig. 5. Basic circuit used for bass lift and cut. $R1=R2$ and $C1=C2$.

Bass-Control Circuit.— Fig. 5 shows the circuit used for bass lift and cut, omitting irrelevant details as before. In order to level response with the potentiometer at mid-setting, and to allow the circuit to be easily combined with the treble-control circuit, $R1$ and $C1$ are made equal to $R2$ and $C2$. At middle and high frequencies the potentiometer is almost “shorted out” by the low reactances of $C1$ and $C2$, so that the circuit becomes almost the same as Fig. 1 with

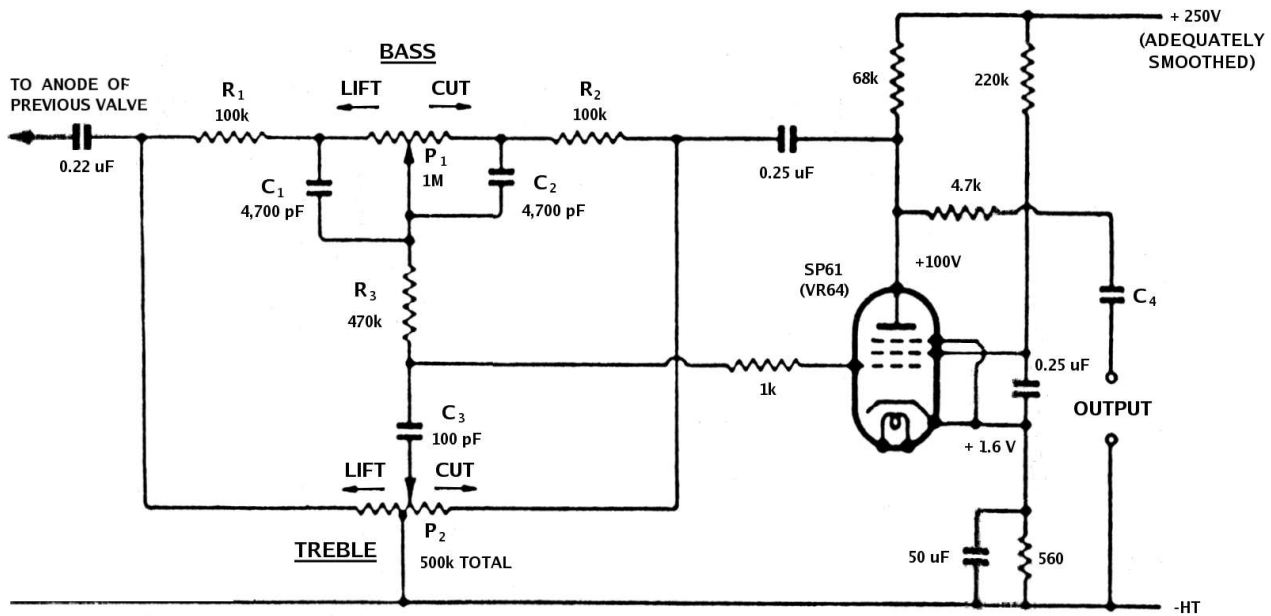

Fig. 6. The complete tone-control circuit. R_1 , R_2 , C_1 , C_2 , R_3 and C_3 should preferably be within 5 per cent of marked values. P_2 is Dubilier Type 'C' control, 500k Ω , with fixed tapping at 50 per cent rotation. C_4 should normally be 0.05 μ F if following stage has 250-k Ω grid-leak.

$R_{in} = R_{fb}$, and a gain of approximately unity is obtained. As the frequency is lowered, the gain gradually rises or falls towards an asymptotic level determined by the potentiometer setting; and, as with the treble-control circuit, the response curves are approximately mirror images in the 0 db line for equal potentiometer displacements either side of the level-response setting. The amount in decibels, by which the gain of the Fig. 5 circuit departs from unity, is given approximately by:—

$$\text{Lift, in db} \approx 20 \log \left(\frac{|Z_{fb}|}{|Z_{in}|} \right) \quad (6)$$

where $|Z_{fb}|$ and $|Z_{in}|$ are the moduli of the impedances between input terminal and grid and between anode and grid respectively. (Note, if an impedance calculated by means of the “j” notation comes out to $R+jX$, the modulus, or magnitude, is $\sqrt{R^2 + X^2}$; see reference 6.) Equation (6) may be used to calculate the response curves, point by point, for various potentiometer settings—a straightforward though time-consuming process! The “cross-over” effect noticeable with some of the measured bass curves shown in Fig. 8 may seem surprising at first, but it is quite genuine and equation (6) gives just the same result.

Complete Tone Control.— Fig. 6 shows the final circuit evolved, which is, effectively, a combination of the treble and bass circuits described above. There is, however, one point about the relation between Fig. 6 and the previous circuits which may need some explanation. At middle and high frequencies, where C_1 and C_2 in Fig. 6 may be regarded as short circuiting the potentiometer P_1 , the relevant part of the circuit becomes as shown in Fig. 7(a). It will be seen that the three resistors R_1 , R_2 and R_3 are connected in a “star” between the three points A, B and C. Now it is well known that, as far as the external circuit is concerned, three resistors in “star” are exactly equivalent to three resistors, of suitably different values, connect in “delta”⁷ so that Fig. 7(a) is equivalent to Fig. 7(b). In Fig. 7(b), the presence of R_c cannot appreciably affect the frequency response, because the resistance is between two points A and B both of which have a relatively low impedance to earth (point A, since the source of input voltage is assumed to be of low impedance; and point B, because it is the output terminal of an amplifier having voltage negative feedback). Hence, ignoring R_c for the above reason, Fig. 7(b) is equivalent to a combination of the treble lift and cut circuits of Figs. 2 and 4, and

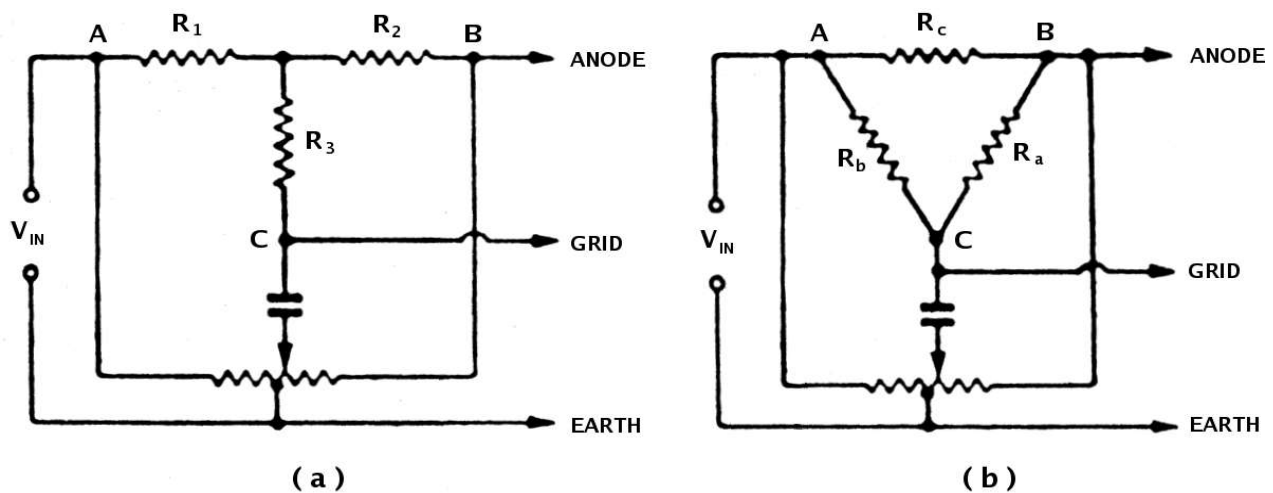

Fig. 7. (a) At middle and high frequencies, the resistors R_1 , R_2 and R_3 of Fig. 6 are effectively connected in "star"; (b) shows the equivalent "delta" network.

therefore Fig. 7(a) is also equivalent to this combination. The relation between star and delta networks is such that if R_1 is made equal to R_2 in Fig. 6, which is essential for giving "mirror image" lift and cut curves, then R_a and R_b in Fig. 7 (b) are each equal to $R_1 + 2R_3$. The important practical result of this reasoning is that the treble response will 3db up or down, at full-lift of full-cut settings respectively, at the frequency for which the reactance of C_3 in Fig. 6 is numerically equal to $R_1 + 2R_3$.

The values of the main components in Fig. 6 were decided as follows. P_1 was fixed at $1\text{ M}\Omega$, this being considered the highest really desirable value for a carbon potentiometer. To give about 20 db asymptotic bass lift and cut, the nearest standard value for R_1 and R_2 was $100\text{ k}\Omega$. A suitable compromise for C_3 was 100 pF , on the grounds that, to obtain a result in accordance with calculation, the value should be large in relation to likely wiring strays, but that too large a value would result in an undesirably low impedance being thrown across the source of V_{in} . The value of P_2 then had to be chosen so that, with the slider half way between the centre-tap and one end the effective internal resistance of the potentiometer, regarding it as a generator feeding C_3 should be not more than say, half the reactance of C_3 at 10 kc/s . Now the reactance of 100 pF at 10 kc/s is approximately $160\text{ k}\Omega$, and using a total value of $500\text{ k}\Omega$ for P_2 , each half is $250\text{ k}\Omega$ and the

internal generator resistance referred to is thus $250/4$, i.e., $62.5\text{ k}\Omega$, which being less than half the capacitance reactance, was regarded as satisfactory. The values of C_1 and C_2 , which must always be equal, were then chosen to position the bass curves at an appropriate part of the frequency scale, and R_3 was selected to do the same for the treble curves.

A high-slope pentode valve was employed in order to obtain a high gain between grid and anode, thereby ensuring close agreement between the measured results and those given by the approximate analysis presented above. A further reason for using a high-slope pentode was that, in a feedback circuit such as this one, where the gain with feedback is almost independent of the actual valve gain, the non-linearity distortion would have been greater if a low-slope pentode or a triode had been used—an important fact which does not seem to be sufficiently widely known.

The circuit as shown in Fig. 6 will deliver an output of 4V r.m.s without introducing more than 0.1 per cent total harmonic distortion, for any signal frequency up to 5 kc/s and at any setting of the potentiometers.

The full-line curves in Fig. 8 show the measured performance obtained with the circuit of Fig. 6. The dotted curves were obtained with the same circuit, except that the centre-tap of P_2 was disconnected from earth. The writer does not regard the dotted curves as being, for normal

purposes, of so desirable a shape as the full-line curves, but since this is a very controversial matter, it may reasonably be claimed as an advantage of the circuit that the alternative curve shapes may be made available merely by adding a single-pole on-off switch.

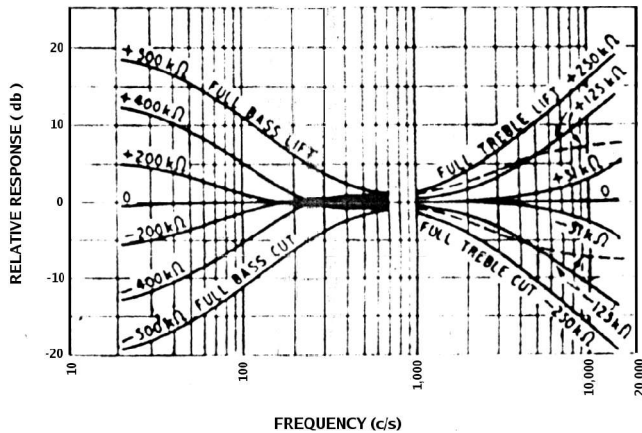

Fig. 8. Measured response curves for circuit of Fig. 6 (all components within 5 per cent of marked values; $C_4 = 0.25\mu F$ with 250-k Ω output load). Labels on curves are resistance values between potentiometer slider and centre of element. Dotted curves are with P_2 centre-tap disconnected from earth.

Associated Circuits.—In conclusion, a few comments on how to incorporate the tone control in preamplifier circuits may be useful. These comments will be of a very general nature, because it is intended, in later articles, to describe the design of suitable preamplifier circuits in detail. The main points are:—

(a) The middle-frequency voltage gain of the tone-control circuit being approximately unity, it may be inserted in a preamplifier without appreciably altering the available gain.

(b) The output impedance of the circuit feeding the tone-control circuit should be reasonably low, preferably not more than about 10 k Ω if the tone-control elements have the values given in Fig. 6. With sources having resistive internal impedances considerably greater than 10 k Ω , R_1 in Fig. 6 may be reduced by an amount equal to the internal resistance of the source; this will give bass-lift, bass-cut and treble-cut curves as published, but less than the published treble-lift will be available.

(c) The output impedance of the tone-control circuit is quite low, because of the voltage

negative feedback, and capacitance up to about 500 pF may be shunted across the output without seriously affecting the performance. This property may be employed usefully if the tone-control stage comes at the output end of the preamplifier, since it will then be possible to use a fairly long coaxial cable to feed the main amplifier, without the need for a cathode-follower output valve in the preamplifier. The feedback loop of the Fig. 6 circuit includes two phase lags at high frequencies, giving rise to a peak in the response at a frequency much above the top of the audio band; the cable capacity on the output lowers the frequency of the peak and greatly increases its magnitude, but the magnitude may be kept small by the addition of a 4.7 k Ω resistor in series with the preamplifier output, as shown in Fig. 6.

(d) The choice of valve is not critical, and for the less exacting kind of application quite satisfactory results may be obtained using half a double triode, e.g., 6SN7 or BCC40. The anode-to-grid capacity will cause the treble-lift curves to depart by several db from the published ones, but this is unlikely to be of much consequence in practice. Because of the high impedance in the grid circuit, it is preferable, when very good signal-to-hum ratio is required, to use a top-grid type of valve. When the signal input level at the input to the tone-control is much less than 1 volt r.m.s., a Mullard EF37A is recommended.

Notes:

1. "Getting the Best from Records—Part III" by P. G. A. H. Voigt, *Wireless World*, April 1940.
2. "Simple Tone Control Circuit" by E. J. James, *Wireless World*, Feb 1949.
3. Section 2.5 of "Waveforms," Book 19 of Radiation Laboratory Series, published by McGraw-Hill.
4. "The See-saw Circuit," by M. G. Scroggie, *Wireless World*, July 1945.
5. "The Anode Follower," by B. H. Briggs, *R.S.G.B. Bulletin*, March 1947.
6. "'j' What it is and How to Use It," by Cathode Ray, *Wireless World*, February 1948.
7. "Electric Circuits and Wave Filters," by A. T. Starr, p. 80 published by Pitman.